

# 232B2-BB

Waterproof Rocker Switch, 30 Amp  
Illuminated DPDT On-On

<https://www.gamainc.com/product/232b2-bb/>

# GAMA ELECTRONICS

P.O. Box 1488, Crystal Lake, IL 60039

Phone: 815-356-9600

Fax: 815-356-9603

Email: [gama@gamainc.com](mailto:gama@gamainc.com)

[www.gamainc.com](http://www.gamainc.com)

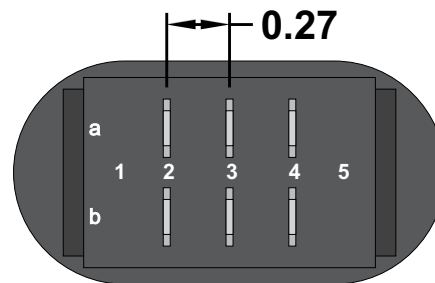
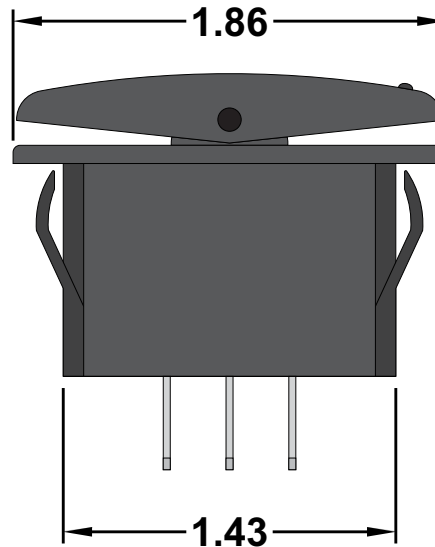
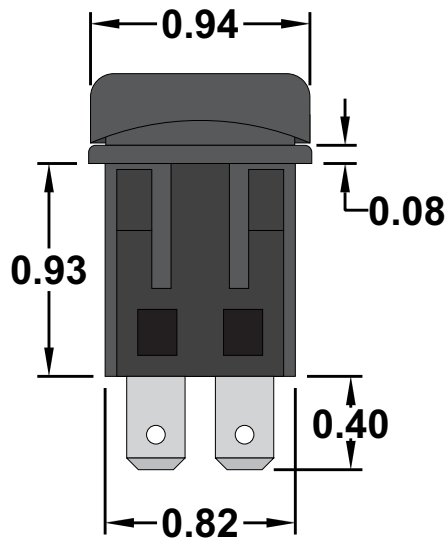
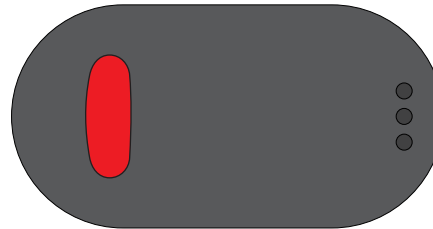

## Available Accessories

- 1-Gang Panel ([232-1G](#))
- 2-Gang Panel ([232-2G](#))
- 3-Gang Panel ([232-3G](#))

## Specifications

- Circuit Code: Double Pole Double Throw On-On
- Rated at 30A @ 12VDC
- Panel Cutout: .82" x 1.44"
- Waterproof to IP66
- UL, CSA & CE Approved

## Circuit Diagram

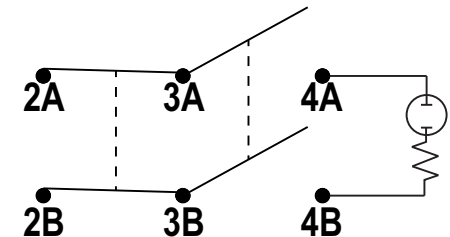

## Mounting Hole

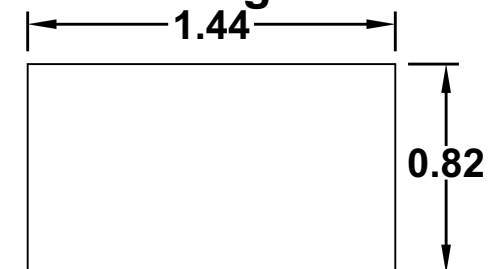

Drawn By: KEG

Information contained herein is proprietary information of GAMA Electronics Inc. The dissemination use or duplication of this information, for any purpose other than that for which the information is provided, is prohibited except by express written permission.

All dimensions are in inches and have a +/- .015" tolerance unless otherwise specified.

Rev: 0

Pg. 1 of 1

Release Date: 10/18/18

Third Angle Projection

