

# 23D-BB

Mini Rocker Switch, 10A SPDT On-Off-On

<https://www.gamainc.com/product/23d-bb/>

## Available Accessories

- 1-Gang Panel [\(66-1G\)](#)
- 2-Gang Panel [\(66-2G\)](#)
- 3-Gang Panel [\(66-3G\)](#)

# GAMA ELECTRONICS

P.O. Box 1488, Crystal Lake, IL 60039  
Phone: 815-356-9600  
Fax: 815-356-9603  
Email: [gama@gamainc.com](mailto:gama@gamainc.com)  
[www.gamainc.com](http://www.gamainc.com)

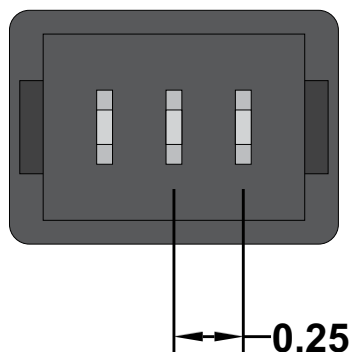
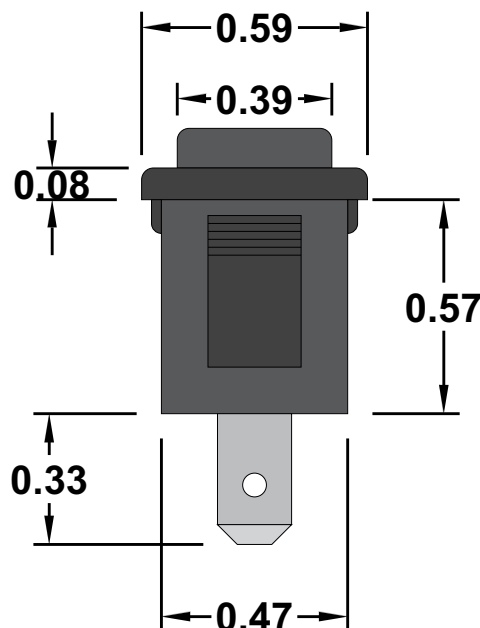
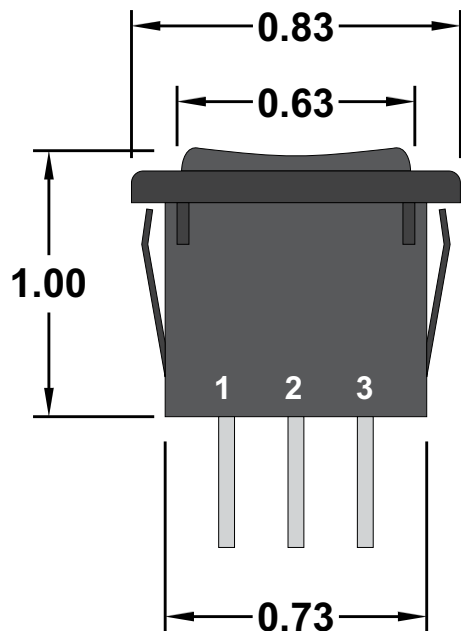

## Specifications

- Circuit Code: Single Pole Double Throw On-Off-On
- Rating: 10A 125VAC, 6A 250VAC, 6A 12VDC
- Terminals: 3/16" Quick Connect
- UL, CSA, & CE Approved
- Black Body & Button

## Panel Cutout

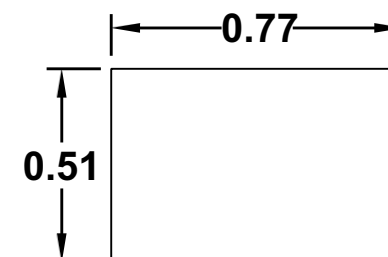

## Circuit Diagram

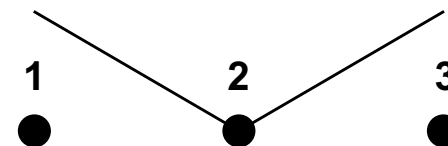

Drawn By: KEG

Information contained herein is proprietary information of GAMA Electronics Inc. The dissemination use or duplication of this information, for any purpose other than that for which the information is provided, is prohibited except by express written permission.

All dimensions are in inches and have a +/- .015" tolerance unless otherwise specified.

Rev: 0

Pg. 1 of 1

Release Date: 08/03/18

Third Angle Projection

