

# 28A-MTD

Toggle Switch, 30A SPST On-Off

<https://www.gamainc.com/product/28a-mtd/>

Standard Switch

## Specifications

- SPST On-Off
- 15A @ 125VAC, 10A @ 250VAC, 30A @ 12VDC, 1 1/2 HP
- Mounts in a .48 diameter hole and it has 1/4 quick connect terminals.
- UL & CSA Approved.

# GAMA ELECTRONICS

P.O. Box 1488, Crystal Lake, IL 60039

Phone: 815-356-9600

Fax: 815-356-9603

Email: [gama@gamainc.com](mailto:gama@gamainc.com)

[www.gamainc.com](http://www.gamainc.com)

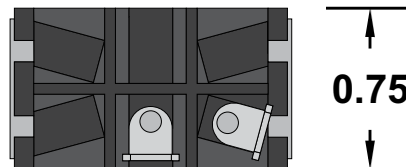
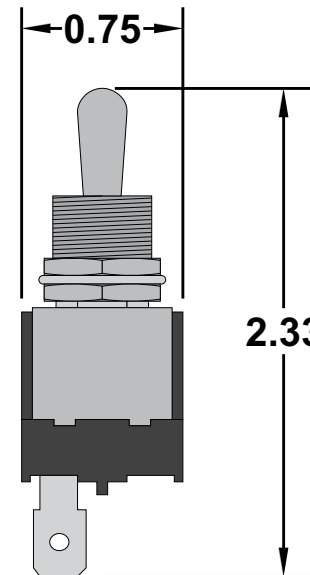
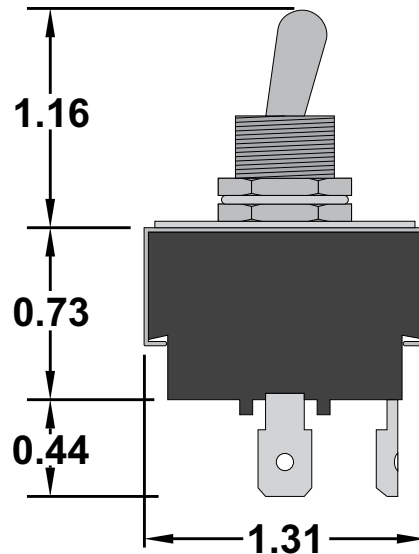
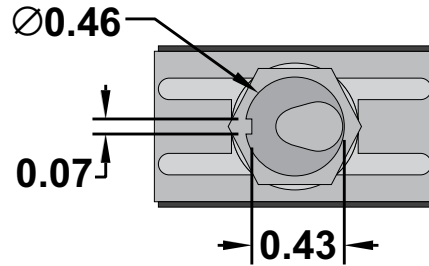

## Mounting Hole

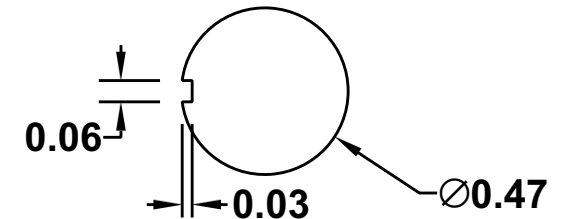

## Circuit Diagram

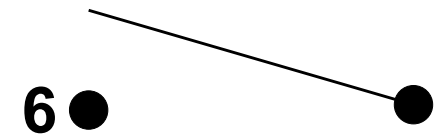

Drawn By: KEG

Information contained herein is proprietary information of GAMA Electronics Inc. The dissemination use or duplication of this information, for any purpose other than that for which the information is provided, is prohibited except by express written permission.

All dimensions are in inches and have a +/- .015" tolerance unless otherwise specified.

Rev: A

Pg. 1 of 1

Release Date: 04/27/20

Third Angle Projection

