

BS100

Side Post Battery Disconnect Switch

<https://www.gamainc.com/product/bs100/>

GAMA ELECTRONICS

P.O. Box 1488, Crystal Lake, IL 60039

Phone: 815-356-9600

Fax: 815-356-9603

Email: gama@gamainc.com

www.gamainc.com

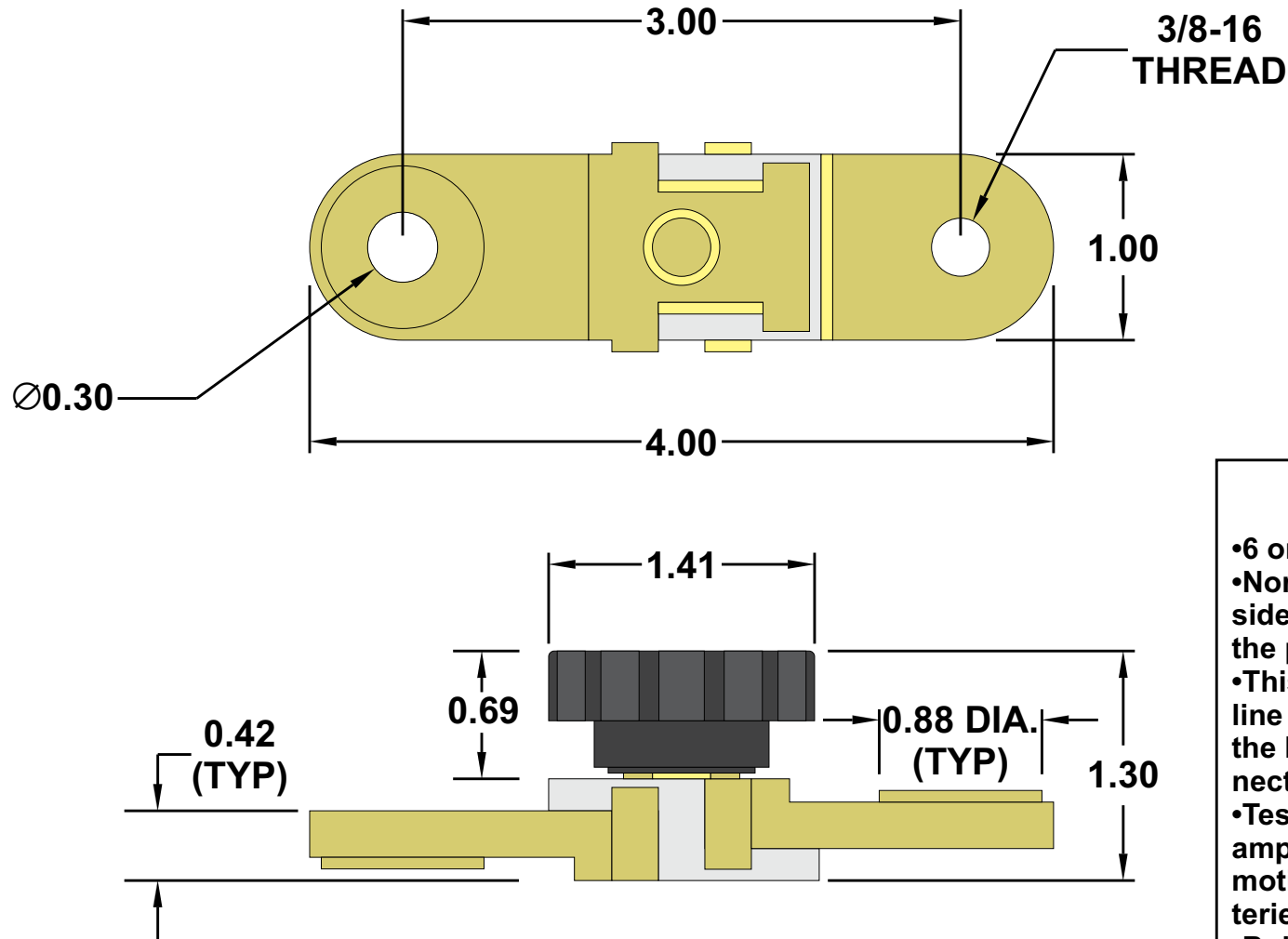

Specifications

- 6 or 12 volt operation.
- Normally connected to the negative side of battery but can be used on the positive side.
- This switch can be used as an in-line device on the negative side of the battery to break the ground connection.
- Tested to exceed a continuous 200 amp load. Will work with any automotive battery regardless of the batteries "cranking amps" rating.
- Bolt M8 x 1.25mm Thread
- Supplied with (1) 3/8-16 x 5/8" Long Hex Head Bolt

Drawn By: KEG

Information contained herein is proprietary information of GAMA Electronics Inc. The dissemination use or duplication of this information, for any purpose other than that for which the information is provided, is prohibited except by express written permission.

All dimensions are in inches and have a +/- .015" tolerance unless otherwise specified.

Rev: 0

Pg. 1 of 1

Release Date: 07/13/20

Third Angle Projection

