

GAMA ELECTRONICS

WWW.GAMAINC.COM

RF24V1C Instruction Manual



Included in this Kit:

- (1) RF24V1C Receiver**
- (1) 2-Button Transmitter** *Image shown with standard transmitter*

Available accessories:

- **Package of A23 12V Alkaline Batteries A23-6**
- **2-Button Waterproof Transmitter KF340-2WP**
- **2-Button Rechargeable Transmitter GKF-WPTX-2**
- **2-Button Keyfob Transmitter KF340-2**
- **340MHz Long Range Antenna LRA-340** *See Page 3 for Setup*
- **Clear Protective Transmitter Pouch ZLB-67**

The RF24V1C is an RF receiver operating at a fixed frequency of 340 MHz. The receiver operates from 24VDC and provides one isolated form C relay contact (normally open and normally closed contacts with one common). Up to thirty, two button keyfob transmitters can be used to activate the receiver's relay. The relay can be configured to function as a latching relay or momentary relay. Each transmitter has a unique address that is transmitted when a button is pressed. A "program" button is provided on the receiver to program the transmitter(s) address into the receiver's memory. The relay mode (latching or momentary) is programmed into the receiver's memory during the programming process. An LED on the receiver indicates the receiver's programming status and illuminates when the relay is energized. The receiver is encased in a small, waterproof enclosure. The typical operating range between receiver and transmitter is up to 100 feet.

"Latching" vs. "momentary" relay operating modes: When the receiver is configured for "latching" mode, the relay will energize when the "UP" button is pressed on the keyfob. The relay will remain energized until the "DOWN" button on the keyfob is pressed. If multiple keyfobs are used any keyfob can energize the relay and any keyfob can de-energize the relay. When the receiver is configured for "momentary" mode the relay will energize and remain energized as long as the "UP" button is pressed on the keyfob. The "DOWN" button on the keyfob transmitter has no effect in this mode

Maximum ratings:

Power for the receiver can be in the range of 21 to 24VDC. The receiver is reverse polarity protected. The relay contacts are electrically isolated from the DC power leads. The relay contacts are rated at 10A @ 30VDC or 120/240VAC.

Power consumption:

10mA when the relay is de-energized. 45mA when the relay is energized

Dimensions:

1.65" X 1.46" X 1.04". The flexible whip antenna extends 3" from the enclosure.

Net weight 2.35 oz. .

Programming Instructions

Each transmitter has its own unique internal address along with the data as to which button is pressed and transmitted. The receiver needs to be programmed to respond only to the specific transmitter it is intended to operate with. The following steps configure the receiver to operate with a particular transmitter. Up to 30 transmitters can be programmed to one receiver. Please read the entire programming procedure before starting. When the receiver enters program mode, all previous transmitter addresses that were programmed will be erased from the receiver's memory.

1. Locate the pushbutton labeled "PROGRAM" on the receiver. Press and hold this button until the red LED next to the program button illuminates (approximately 3 seconds). The receiver is now in the transmitter program mode. Release the button. At this point all previously programmed transmitter addresses are erased from the receiver's memory.
2. To configure the receiver for a latching output, go to Step 4.
3. To configure the receiver for momentary output, press and release the UP button on the transmitter and verify that the red program LED extinguishes and then illuminates (blinks once). Proceed to Step 5.
4. To configure the receiver for latching output, press and release the DOWN button on the transmitter and verify that the red program LED extinguishes and illuminates (blinks once).
5. Repeat previous step for additional transmitters that will operate with this particular receiver. The red LED on the receiver will extinguish and illuminate (blink) once for the first transmitter being programmed, twice for the second, three times for the third, etc. The receiver will not respond to transmitters that have already been programmed. The first transmitter that is programmed determines the receiver's relay operating mode.
6. The receiver will return to normal mode if no transmitter buttons are pressed for 5-seconds. The red LED on the receiver will blink rapidly, then extinguish. The receiver is now in the normal mode of operation. This completes the programming instructions. The receiver will retain all of its programming even when power is removed.

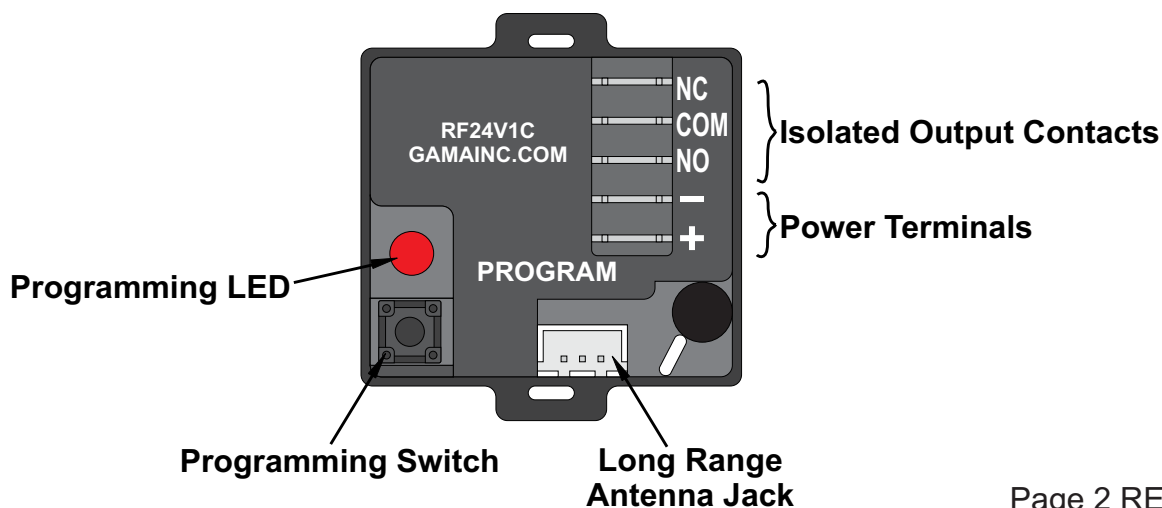

To Add Long Range Functionality

The remote control system is equipped with an internal antenna. The expected range in normal conditions is approximately 100 feet. When additional range is needed, or if the control is placed locations adverse to RF signal reception, a long range antenna can be added to the system. GAMA Electronics long range antenna, part number LRA-340, replaces the internal antenna on the system. In normal operating conditions expected range is greater than 500 feet. If the long range option is purchased with the system, this modification will be made prior to shipment.

NOTE: ONCE THE LONG RANGE MODIFICATIONS HAVE BEEN MADE TO THE SYSTEM THEY CANNOT BE REVERSED.

To add long range functionality:

1. Plug long range antenna (Part number LRA-340) into the long range antenna jack.
2. Clip the Long Range Antenna Bypass Wire (This will deactivate the internal antenna)

NOTE: It is recommended that you cover the exposed wires with RTV silicone sealant.

Wiring Diagram

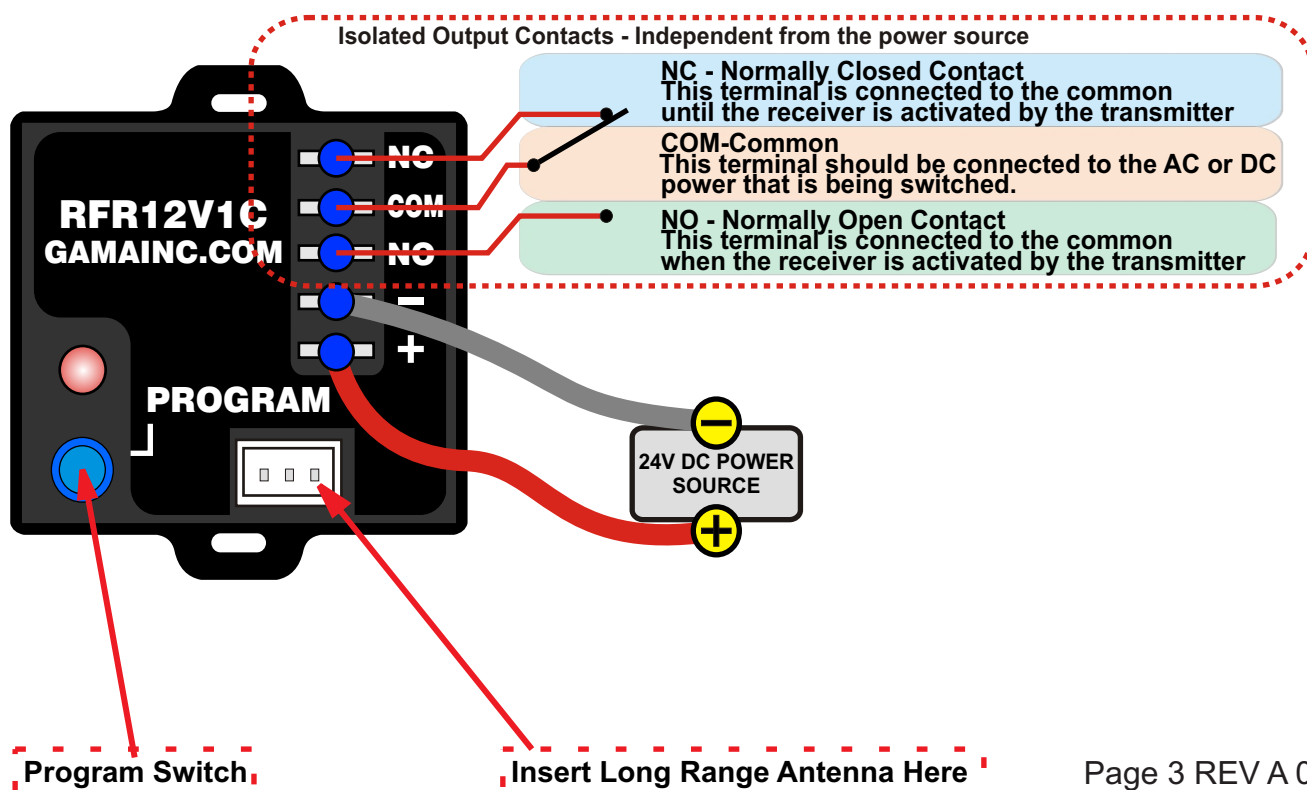

Troubleshooting

All remote-control systems shipped by GAMA Electronics are 100% functionally tested just prior to shipment.

If your RF remote control system does not work out of the box, stops working or functions intermittently please take the following steps to resolve common issues. Please note that you must be 2-3 feet away from the receiver when operating the remote control. Operating within 2-3 feet may result in no operation or intermittent operation.

1. Replace the A23 12V Battery in the transmitter

- The remote control can activate during shipping and drain the battery that is installed in the control. We send a replacement battery with the system if this occurs.

2. Check the voltage supply at the receiver

- The receiver is designed to function at 21-24VDC. Voltage on the (+) and (-) terminals on the control should be within this range.

3. Reprogram the remote control

- If the system is non-functional try to reprogram the remote control. The program may not have taken during the programming process or the program button may have been pressed. If the program button is pressed the memory of the remote controls programmed to the receiver are erased.

4. Listen and look for functionality on the receiver.

- The LED that is used for programming the system will illuminate when the receiver is activated. You will also hear a “click” when the internal relays engage. If you can see the LED illuminate and you hear the relay “click” the issue is most likely in the wiring or device being controlled.

5. Add a long-range antenna

- If the receiver is in an area that is averse to the reception of an RF signal, such as near a motor or in a metal casing, a long-range antenna may solve the issue. Connect the antenna per the instructions on page 3 and mount the antenna in an exposed area away from any motor.